

Introducing a Portable Level Gauge for Ballast Tanks!

This is the world's first commercialized portable air-purge type level gauge to be based on Musasino's Level Aeran 2, which has been successfully used on numerous ships around the world.

With a touch of a button, this portable gauge senses the changes in the air pressure of the flexible tube inserted into the sounding pipe, and quickly measures the depth of the ballast water (sea water).

Measuring with a sounding tape, which has been the common method, required time in preparation, lowering and raising the tape, and placed a great strain on those performing the work.

Using this portable gauge can **dramatically reduce the measurement time, and the labor involved in taking the sounding.**

In addition, it promotes **efficient and safe cargo handling, and the productive use of the crew.**

Features and Results

- 1 Small (35cm wide x 33cm tall x 23cm deep) and lightweight (approximately 5kg) it is easily moved

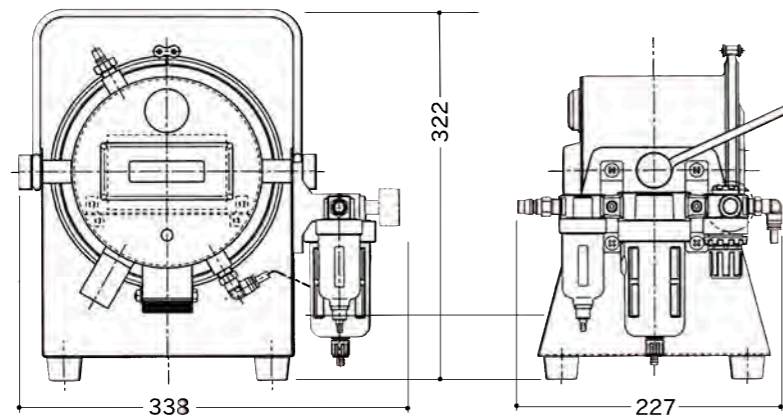

- 2 A tank can be measured in about 10 – 15 seconds
- 3 Designed for use on most ships (one touch connection between the detector body and air hose)
- 4 Automatic pressure sensor element adjustments correct for temperature and pressure changes for high accuracy
- 5 Powered by a 9V dry cell battery, so no need for an external power connection (equipped with an automatic shut off to prolong battery life)
- 6 Digital display

System Architecture

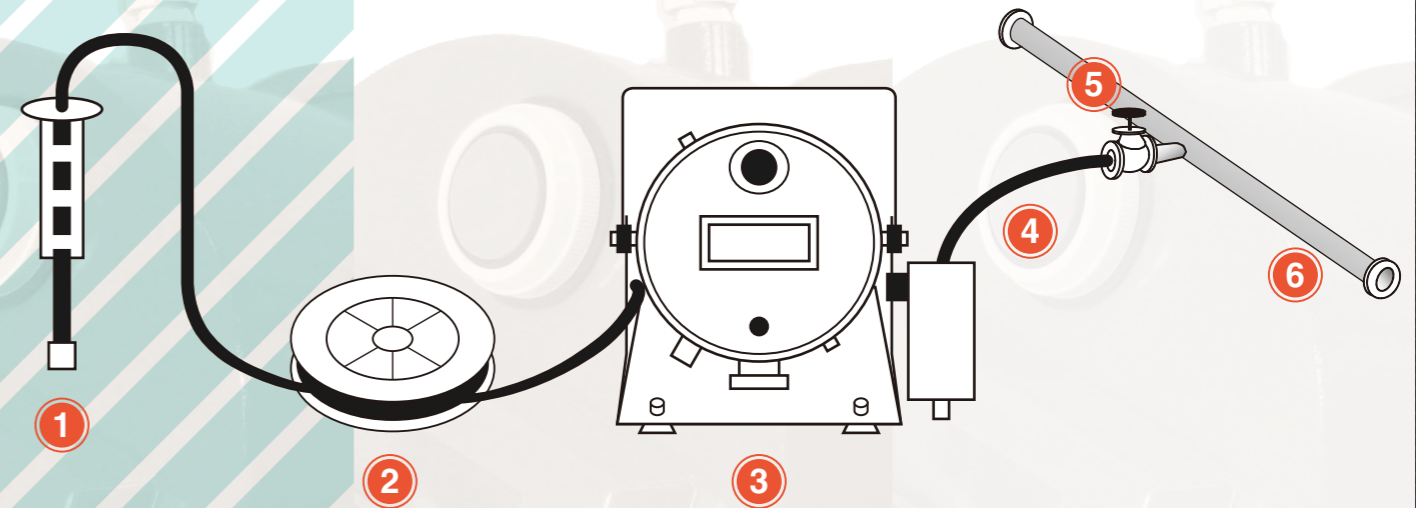

- 1 **Sounding Pipe (deck mounted)**
- 2 **Purge Tube (reel)**
4mm Internal Diameter Polyurethane Tube
Purge Mouth
- 3 **Detector**
Air Supply Control Solenoid Valve
Pressure sensor (built-in)
Display (built-in)
Start Button (built-in)
Blow Button (built-in)
Tube with Coupler (external)
Air Supply Unit (external)
- 4 **Air Supply Hose (deck mounted)**
- 5 **Stop Valve (deck mounted)**
- 6 **Air Supply Pipe (deck mounted)**



LEVEL PORTA

World's First Portable Air-Purge Type Level Gauge for Ballast Tanks